

## Probst SG 80 Block Grab

### Safety Information and Operating Instructions

#### 1.0 General Information

- The Block Grab is designed for the gripping and transportation of vertically steel strapped packs paver blocks, kerb stones, slabs and wall blocks.
- **Marwood Group Ltd recommends the use of a 1mtr x 5.3t single leg chain sling for attaching the grab to the crane or excavator.**
- **Marwood Group Ltd also recommends the use of safety nets underneath the suspended load.**
- **The SG80 must not be used to suspend dumpy bags.**

Type	Gripping Range (mm)	Inside Height (mm)	Gripping Length (mm)	Carrying capacity (kg)	Dead weight (kg)
SG 80 restraint	600 - 1100	800	1200	1800	200

#### 1.1 Schematic of the SG 80 Block Grab

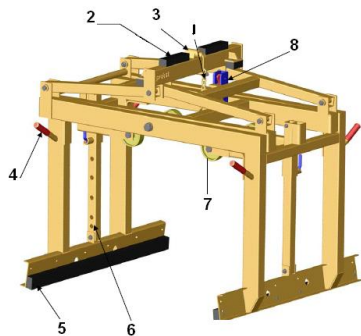

1	Limiting chain for minimum opening range
2	GMT-bar as cushioning
3	Clamping bolt for support frame
4	Handle
5	Rubber gripper bar
6	Adjustable inside height
7	Adjustable support
8	Automatic release (with operating delay)

#### 2.0 Safety Instructions for the Block Grab

- Only qualified authorised personnel, wearing appropriate PPE as required by Risk Assessment should be allowed to operate and check this equipment.
- The area where the device will be used must be segregated to prevent unauthorised access.
- The SWL stated must never be exceeded.
- All body parts must be kept well clear when using these grabs.
- Lifting above head height should be in conjunction with a correctly fitted safety net.
- Ensure the workplace is sufficiently illuminated.
- Do not lift products off-centre as the grab may drop the load.
- The block grab must not be use to grip non-rectangular loads and round loads.
- Never suspend any load with ropes, chains or similar attached to the equipment.
- Take care in case of thunderstorms.
- Take care when handling wet, dirty and products not solidified.
- Never lift products or components with foil or plastic packaging.
- The device must never be used to transport animals or people.
- Avoid quick or jerky movements with the device e.g. **driving fast over uneven ground as the load may drop.**
- The device must never be subjected to a force acting in a lateral direction due to a diagonal pulling.

- Do not use the grab if there are any cracks, splits or damage to the equipment.
- Never open the grab if the gripping arm is blocked by resistance.
- **The use of this equipment is not recommended below 37.5°F or 3°C as load may fall in freezing conditions.**
- **The SG80 must not be used to suspend dumpy bags.**

### 3.0 Setting the Height Adjuster

1. With one hand, hold the adjustable support and with the other hand rotate the spring bolt about 180° releasing the bolt.
2. Adjust the height of the adjustable support by hand.
3. Release the spring bolt ensuring it fully engages into one of the defined positions.
4. Take care, that the lower edge of the rubber grippers is aligned with the lower edge of the load.
5. Always engage the spring bolt after adjusting the height of the support.  
Danger of accidents!

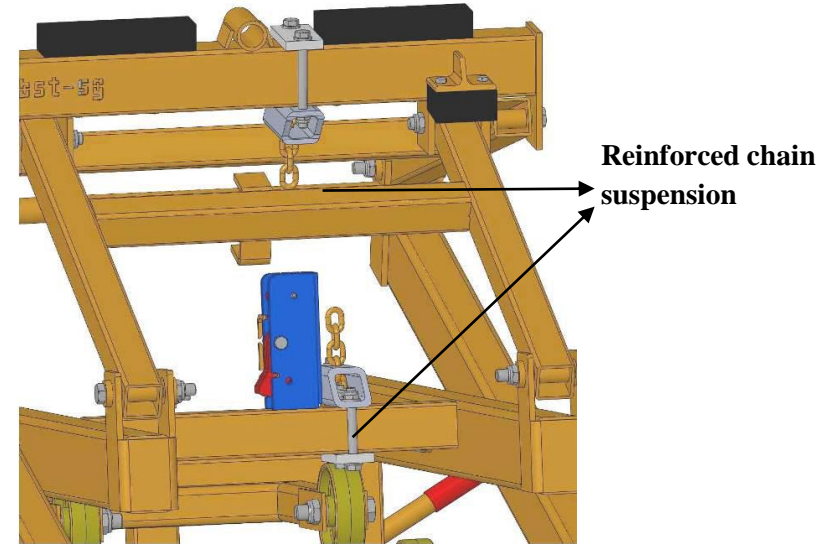
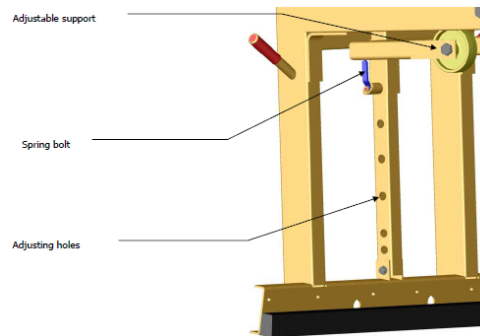

### 5.0 Automatic release of grab

- The automatic release with operating delay avoids an involuntarily unlocking of the automatic release and therefore the closing of the grab.
- The reason that the grab closes is due to fast driving over uneven ground.

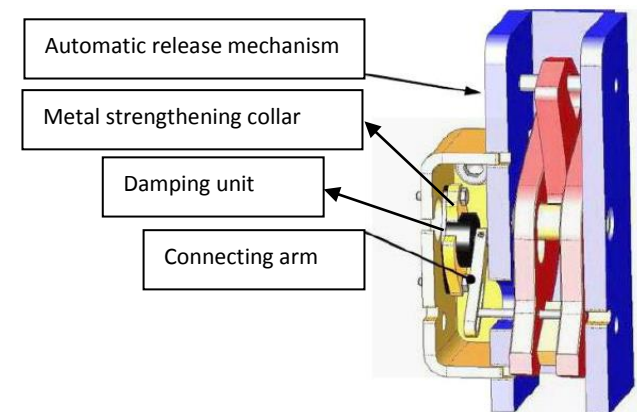

### 4.0 Reinforced Limiting Chain Suspension of the block grab

- The limiting chain is to prevent the grab fully closing in the unlikely event of the automatic release involuntarily operating.

## 5.1 Testing of Rotation Brake

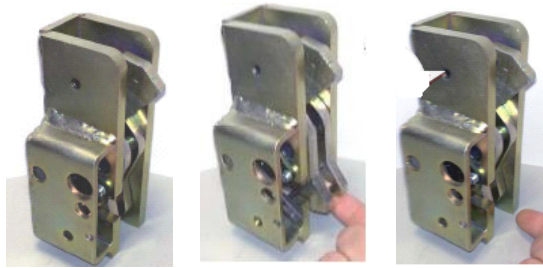

- Basic position of the rotation brake (before the function test)
- Raise the automatic release with one finger and then let it go.
- Ensure the unit travels the full required distance, lubricate where necessary.

**Note:** If the rotation brake returns to its basic position in less than 2 seconds, the automatic release part must be exchanged.

## 6.0 Net Hooks

There must be four net hooks sidewise on the grab. They are welded. The pair on each side should be relatively far.

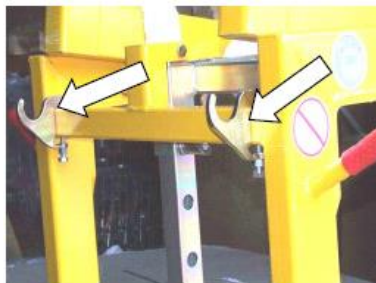

## 6.1 Use of Safety Net

A safety net must be used whenever a load is to be transported above head height or in any situation where a safety net would otherwise be appropriate.

Before use, the safety net must be inspected for any damage, cuts or security concern. The metal bar across the safety net must sit and align on the hooks. Ensure that the safety net is also attached to each side/pivot hook, which will remove any slack in the net, ensuring should the load fail the contents will be caught by the net. The net must enclosed the four legs as shown in photo. If in any doubt about usage of the safety net with Block Grab in a particular situation, consult the site Health & Safety Officer.



## 7.0 Operating the Block Grab

- Do not use the grab without a current report of thorough examination.
- The grab must be inspected daily, using the information given in this leaflet and report any faults to your supervisor.
- Before using the device, check the functions and the working conditions. The user must ensure that the equipment is suited to the intended operation, the functioning and the working condition of the equipment is examined, and the loads are suitable to be handled.
- The grab is first connected to the lifting equipment (e.g. Crane )
- Before any lifting operations set the height adjusters must be set for the appropriate pack size, ensuring that the rubbers align with the lower edge of the load.
- Ensure that the grab is placed centrally over the load and set down ensuring the rubber grippers are aligned with the lower edge of the load.
- The latter closes round the product once the grab is raised.

- When the grab is set down again, it will open automatically.
- The automatic release locks it into position so that the grab can be lifted without closing up.
- The same procedure above is repeated over the next product to be lifted.
- For height operation of the grab, a security net suspended underneath the load is recommended. Contact Marwood Group for more information.

**Note:**

- 1. The block grab is a ONE MAN OPERATION MACHINE.**
- 2. To prevent danger of overturning, the gripping arms must be opened enough to ensure a secure standing of the device positioned on flat and firm ground ONLY**
- 3. The forks of the lifting device must be tilted a little to the rear for safe transportation.**

**8.0 Pre use checks**

- The daily check should be only carried out by a competent person.
- The overall appearance and condition of the Block Grab must be checked. Examine all welds for any signs of cracking.
- Lifting eye must be checked for any cracks, pitting, twisting, stretching & wear to the lifting eye.
- The main frame and gripping arms must be straight without any fractures.
- Automatic release mechanism must be checked for damage, wear, dirt or bent pins.
- Bolts must be inspected for wear, distortion, stretching, and or twisting.
- Examine all chains for security of both the clamp and the chain attachment points, also for signs of wear, distortion and or stretching.
- The scissor pivot pins must be inspected for any damage, wear, security. They must be lubricated were necessary.
- Check height adjuster's for any damage or distortion. Check the spring bolt and lubricate where necessary. Adjust to the correct height of the pack being lifted with the rubbers aligned with the lower edge of the pack.

- Check rollers and shafts condition for any sign of wear and damage.
- Examine the gripping rubbers for signs of wear, damage and security to the back plate. Ensure that both back plates are straight.
- Check condition & security of grab handles. Inspect and check welds of safety net retaining hooks for any sign of wear, distortion and corrosion.

Should any problems / faults arise from the pre-use checks the unit must be with drawn from service and immediately contact the nearest Marwood Group Ltd Depot.

**9.0 Maintenance of the SG 80 Block Grab**

- Maintenance and lubrication are only permitted when the device is stationary.
- This equipment will be subjected to a thorough examination by a competent person at six monthly intervals.
- All maintenance operation must be made in a closed state of the device.
- Lubricate where necessary all joints.
- Under no circumstances should grease be used to lubricate the automatic release mechanism. Check for signs of wear to the unit.**(USE OIL INSTEAD IF NEEDED!!)**
- The automatic release must be kept clean at all times.
- If the automatic release has a fault, there might be need to change the inset.
- Check all joints, bolts for signs of damage, wear or stretching.
- Never remove data plates of the device.
- The limiting chain and its attachment points should be inspected for wear, security, pitting corrosion or any unusual appearance such as extended links.
- Unrecognisable data plates must be replaced immediately.
- Check condition and security of gripping rubbers, report damage to your local Marwood Group Depot. Make sure to clean the gripping rubbers, ensure the load is free from contamination.
- Grease all sliding's.
- If the opening path of the gripping arm is blocked by resistance, seek advice from trained personnel.

Should any faults or damage occur to the device please remove from service immediately contacting or returning to your nearest Marwood Group Ltd Depot.

**This equipment must not be modified or dismantled.**  
**A full copy of the manufactures operating and safety instructions may be downloaded from [www.marwoodgroup.co.uk](http://www.marwoodgroup.co.uk) or contact your local Marwood Group Ltd Depot**