

<b>Customer name</b>	
<b>Contract number</b>	

<b>STATUS</b>	<b>Final / On Hire</b>		<b>Off-Hire</b>		<b>Stock Transfer</b>		<b>Thorough Examination</b>		<b>Job sheet</b>	<b>DATE</b>
---------------	------------------------	--	-----------------	--	-----------------------	--	-----------------------------	--	------------------	-------------

<b>PLANT NUMBER</b>		<b>DESCRIPTION / TYPE</b>	
---------------------	--	---------------------------	--

**THESE INSTRUCTIONS SHOULD BE FOLLOWED WHEN CHECKING EQUIPMENT**

- Check the general appearance including paint finish.
- Inspect the equipment for any damage to the frame work.
- Check that all nuts, bolts, spring/rail plungers, and R-clips are present and are in good condition.
- Inspect all the welds for signs of cracking.
- Check the condition of the lifting points and check for any damage or security concern.
- Ensure that the door operates smoothly (lubricate where necessary) and it always returns to the closed position. Check the gate stop plate condition and operation.
- Check that the clamps holding door hinge are tight.
- Examine the condition of the floor for any damages, including the lifting shackles (old version).
- Examine the fence panel including mesh for sign of damage, distortion and pitting corrosion (old version).
- Examine the clamps, ensure that the bolts are clean and free to operate smoothly.
- Check that all Marwood and safety stickers MGS 24, SWL 135kg MGS98 are present.
- Check and record plant number, serial number and SWL if applicable.

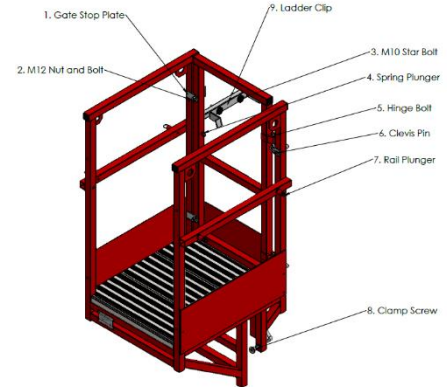

Any inspection points that are not applicable or do not match an old platform type, write N/A or more details. Do not leave blank. Data plate with SWL is present on the new Alite Access platform.

**Equipment which displays evidence of incorrect operation should be withdrawn from service.**

	<b>OK</b>	<b>R</b>	<b>COMMENTS</b>
<b>GENERAL APPEARANCE</b>			
Main Frame			
Condition of nuts, bolts, plungers and R-clips			
Condition of welds			
Condition of lifting eyes			
Check door & operation			
Security of door hinge			
Condition of floor & shackles			
Condition of fence panels			
Clamping bolts			
Marwood and safety labels present as per above			
Record plant no, serial, SWL			
<b>Entered on computer system</b>			<b>The results of all off hire inspections must be entered onto the computer system.</b>

**Equipment should be cleaned and correctly stored after checking**

**CHECKED BY:**

**DATE:**

<b>PRINT</b>	<b>SIGN</b>
--------------	-------------