

Customer name	
Contract number	

STATUS	Final / On Hire		Off-Hire		Stock Transfer		Thorough Examination		Job sheet	DATE
---------------	------------------------	--	-----------------	--	-----------------------	--	-----------------------------	--	------------------	-------------

PLANT NUMBER		DESCRIPTION / TYPE	
---------------------	--	---------------------------	--

THESE INSTRUCTIONS SHOULD BE FOLLOWED WHEN CHECKING EQUIPMENT

- Check the general appearance including paint finish.
- Inspect the equipment for any damage to the frame work.
- Check that all nuts, bolts, spring/rail plungers, and R-clips are present and are in good condition.
- Inspect all the welds for signs of cracking.
- Check the condition of the lifting points and check for any damage or security concern.
- Ensure that the door operates smoothly (lubricate where necessary) and it always returns to the closed position. Check the gate stop plate condition and operation.
- Check that the clamps holding door hinge are tight.
- Examine the condition of the floor for any damages, including the lifting shackles (old version).
- Examine the fence panel including mesh for sign of damage, distortion and pitting corrosion (old version).
- Examine the clamps, ensure that the bolts are clean and free to operate smoothly.
- Check that all Marwood and safety stickers MGS 24, SWL 135kg MGS98 are present.
- Check and record plant number, serial number and SWL if applicable.

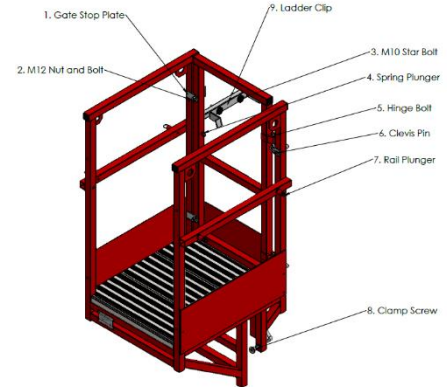

Any inspection points that are not applicable or do not match an old platform type, write N/A or more details. Do not leave blank. Data plate with SWL is present on the new Alite Access platform.

Equipment which displays evidence of incorrect operation should be withdrawn from service.

	OK	R	COMMENTS
GENERAL APPEARANCE			
Main Frame			
Condition of nuts, bolts, plungers and R-clips			
Condition of welds			
Condition of lifting eyes			
Check door & operation			
Security of door hinge			
Condition of floor & shackles			
Condition of fence panels			
Clamping bolts			
Marwood and safety labels present as per above			
Record plant no, serial, SWL			
Entered on computer system			The results of all off hire inspections must be entered onto the computer system.

Equipment should be cleaned and correctly stored after checking

CHECKED BY:

DATE:

PRINT	SIGN
--------------	-------------