

## SPECIFICATION SHEET

# Road Plates

Refer to table on second page of this document for dimensions, weights and to determine which one has the center lift plate and fixing points

Road Plates are used to temporarily bridge excavations to open the carriageway to vehicular traffic, typically during traffic sensitive periods or at night/weekends.

Fitted with a central lifting point, welded by Marwood coded welders. Lifted using a dedicated Steel Plate Lifter, making the plate safer and easier to handle by lorry-mounted crane, than conventional methods.

With four fixing points for the RPbolt/lock system (M16) supplied with collar & bolt as HIRE ACCESSORIES and finished off with a SALE ONLY plastic cap. (As this system does not fit all road plates' check before order and delivery.) The RPbolt/lock system is suitable for both concrete and asphalt.

### Marwood Notes

- ❖ All steel plates are Grade s275JR
- ❖ Pedestrian usage: 13mm (1/2") thickness (guide information)
- ❖ Vehicular usage: 19/20mm (3/4") or 25mm (1") thickness. (guide information)
- ❖ All road plates must be stored on flat surface with wooden bearers between each plate to protecting the finish from fork damage
- ❖ The use of road plates should be planned in advance. An assessment will be required to identify the appropriate size and thickness of plate to be used. It is the customer's duty to carry a full and specific risk assessment before hiring or buying road plates
- ❖ Marwoods do not provide any data on loading and deflection the plates can take and withstand. Customer must contact their structural engineers before hiring/buying
- ❖ The current Safety at Street Works and Road Works Code of Practice does not specify how anti skid road plates should be fitted to the ground. Road plates must (have chamfered edges), (integral ramps), (be sunk into the surface) or (have a suitable bitumastic material) to provide a ramp to the plate level. Where ramps exceed 15 mm in height, appropriate ramp warning signs should be used. The road plate must be secured when in use
- ❖ All rendered images are for illustrative purpose only. Actual equipment may vary. Specifications will have the standard MWG tolerance of 0.5%
- ❖ All related documents are subjected to changes for continuous enhancement and improvement

STOCK NO. RP21

ROAD PLATE (1.85M X 1.25M X 13mm) 233kg

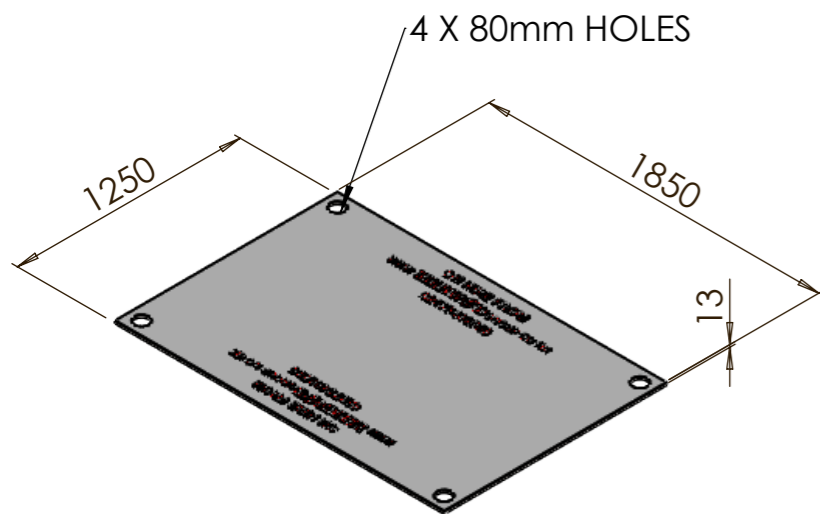

STOCK NO. MW-RP4AS

ANTI SLIP ROAD PLATE (1.25M X 1.25M X 19mm) 233kg

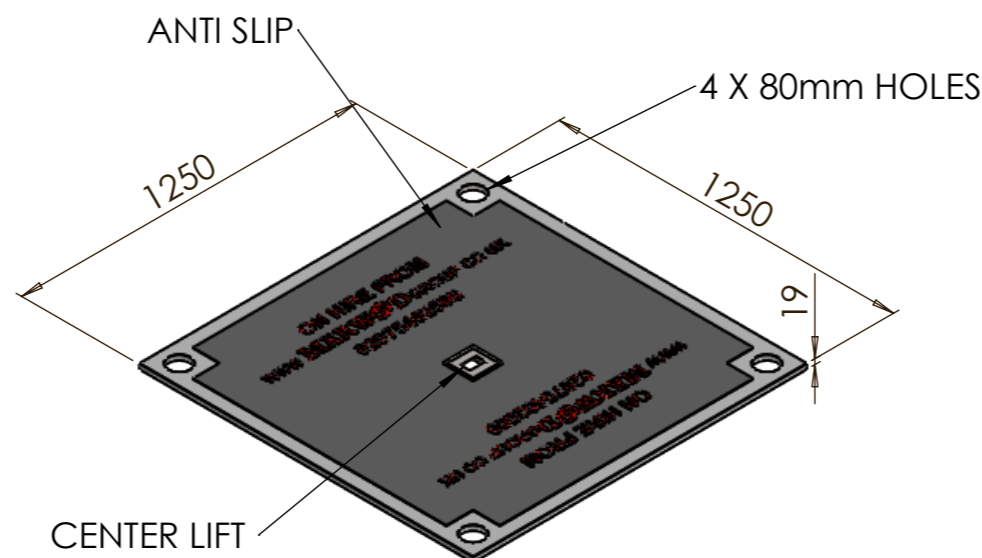

STOCK NO. MW-RP33AS

ANTI SLIP ROAD PLATE (2.4M X 1.25M X 19mm) 504kg

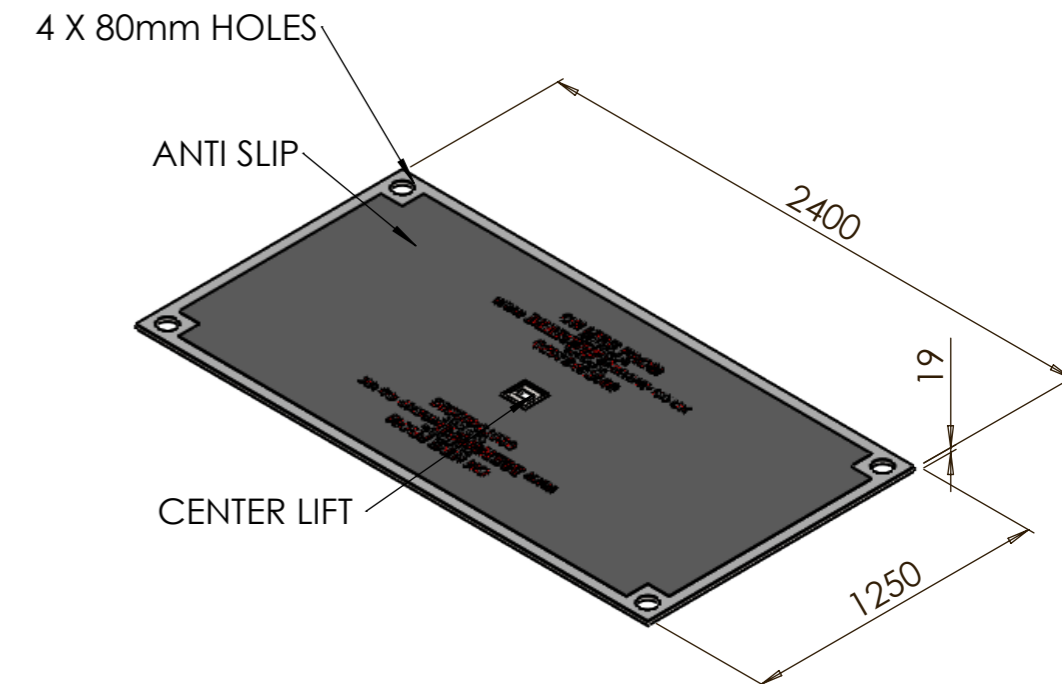

STOCK NO. RP23 (WHITE)

ROAD PLATE (1.85M X 1.25M X 19mm) 340kg

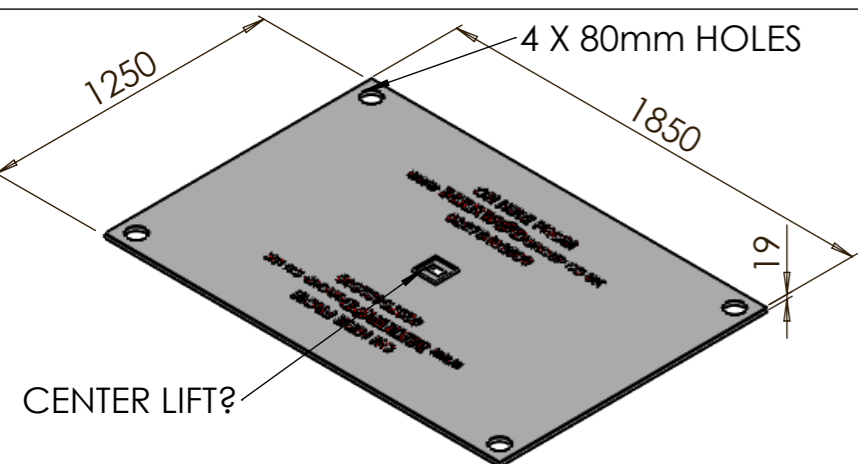

STOCK NO. RP24

ROAD PLATE (1.85M X 1.25M X 25mm) 447kg

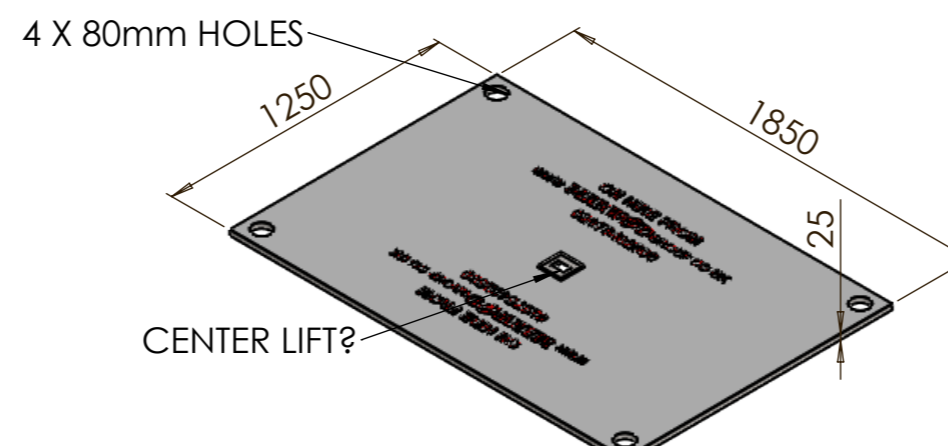

STOCK NO. RP3

ROAD PLATE (1.25M X 1.25M X 13mm) 156kg

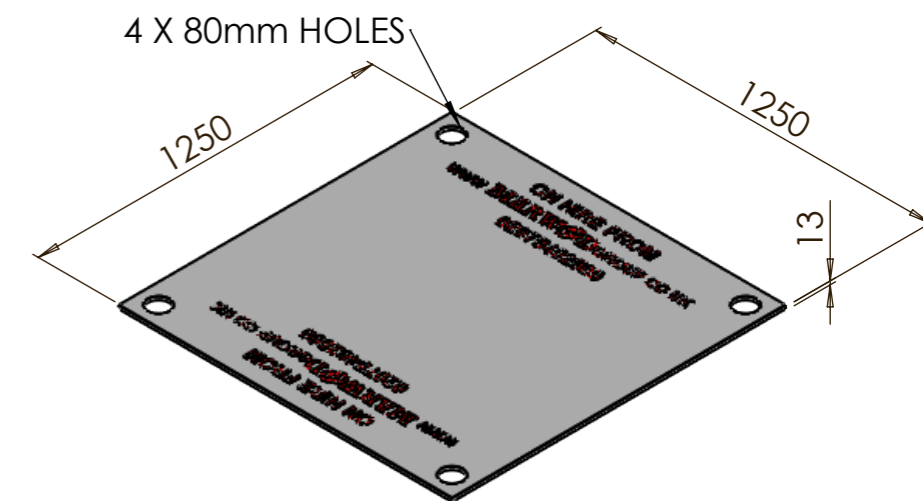

STOCK NO. RP33 (WHITE)

ROAD PLATE (2.5M X 1.25M X 19mm) 461kg

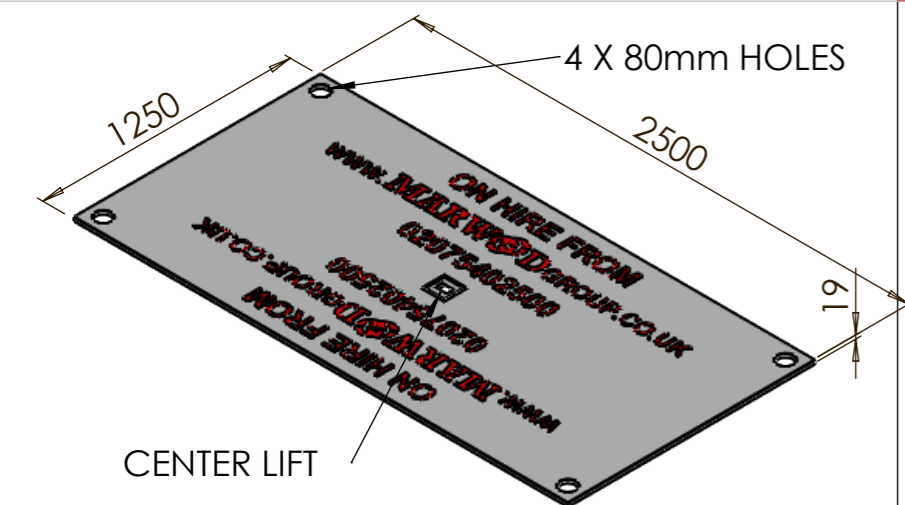

STOCK NO. RP32

ROAD PLATE (2.5M X 1.25M X 13mm) 315kg

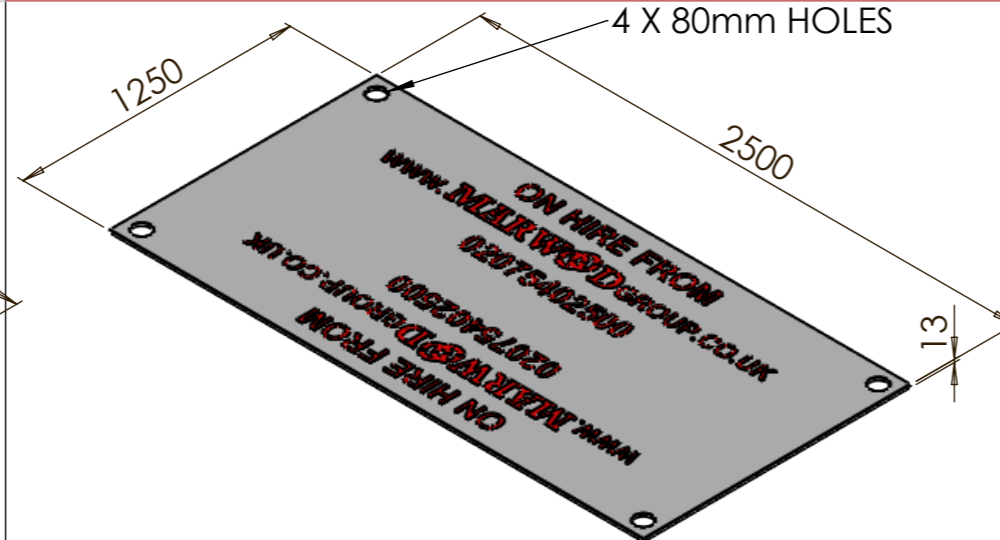

(BAUXITE COATING may be present) STOCK NO. RP33AS  
ANTI SLIP ROAD PLATE (2.44M X 1.25M X 19mm) 495kg

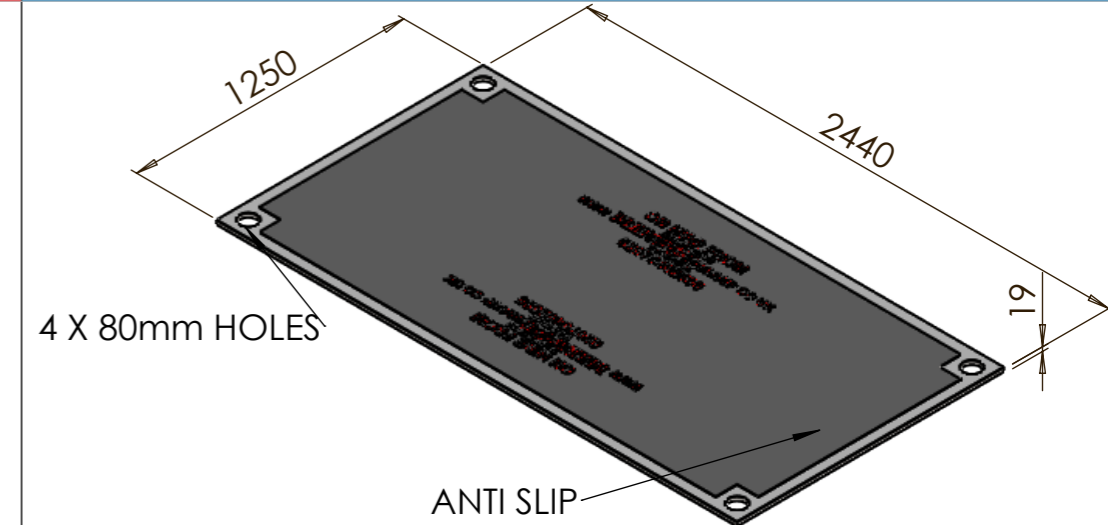

MAY OR MAY NOT HAVE CENTER LIFT

All weights and dimensions have a tolerance of plus minus 0.5%  
Renders are for illustration purpose only  
Information on this sheet is correct on date published

**STOCK NO. RP34**  
**ROAD PLATE (2.5M X 1.25M X 25mm) 606kg**

**STOCK NO. RP54**  
**ROAD PLATE (3.75M X 1.25M X 25mm) 910kg**

**STOCK NO. RP4 (WHITE)**  
**ROAD PLATE (1.25M X 1.25M X 19mm) 229kg**

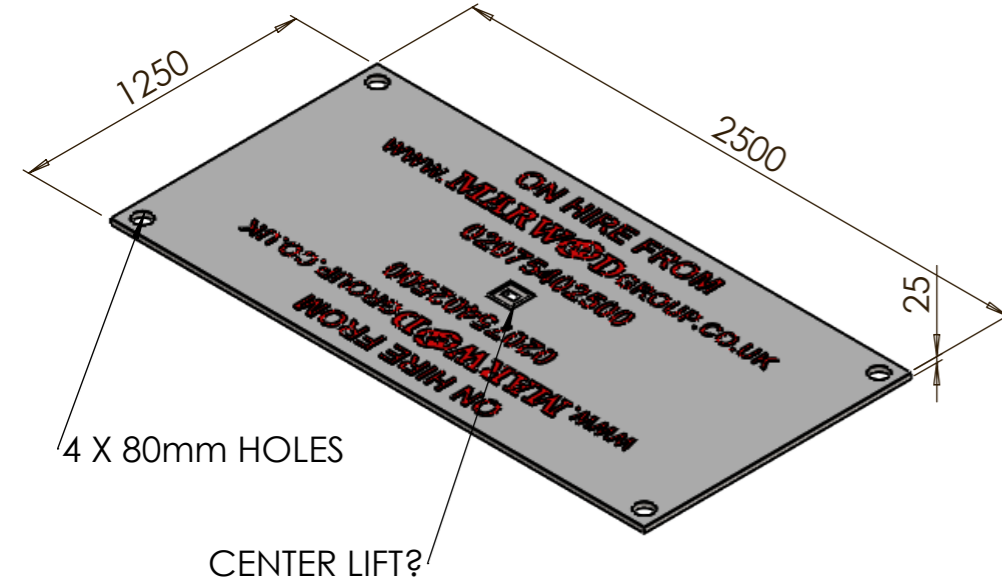

MAY OR MAY NOT HAVE CENTER LIFT

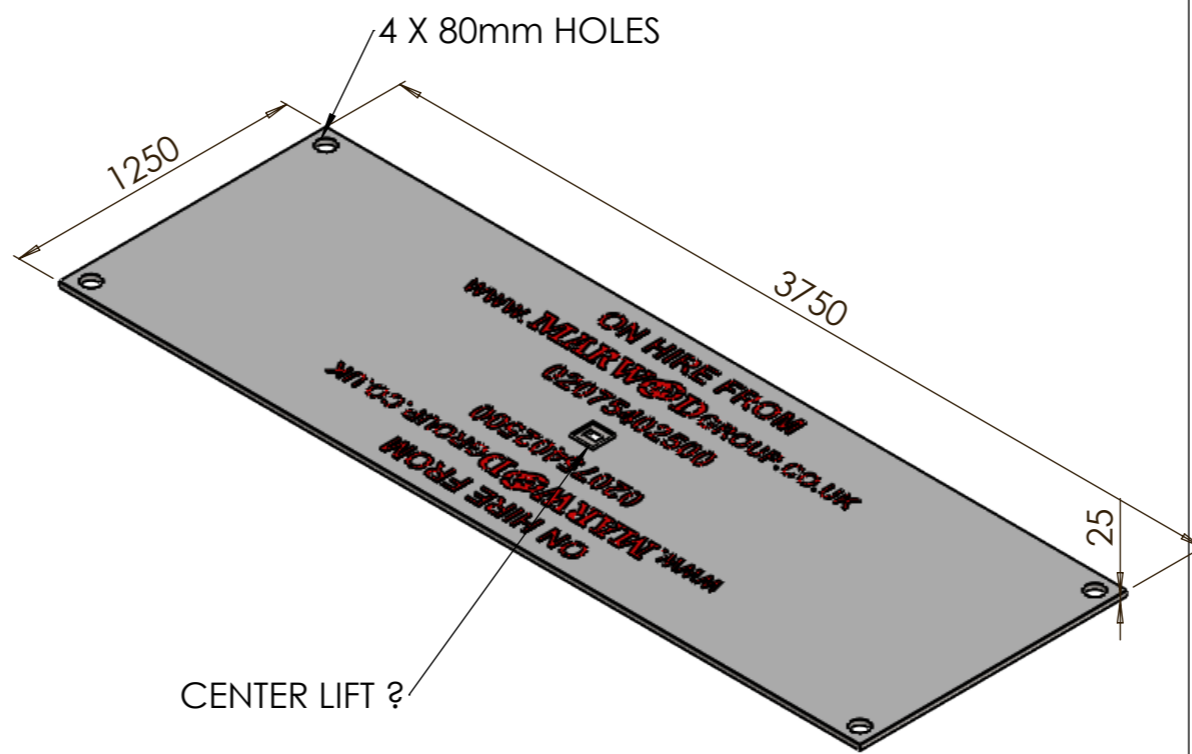

MAY OR MAY NOT HAVE CENTER LIFT

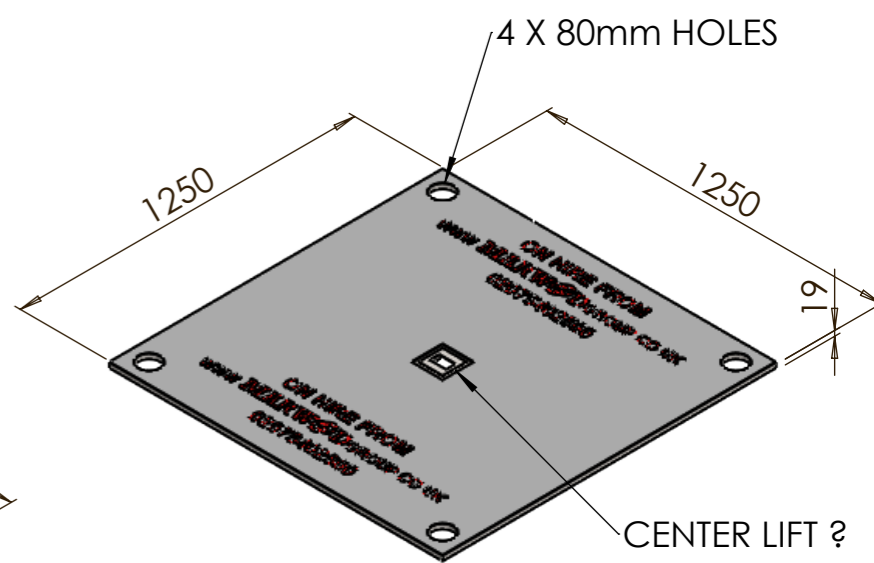

MAY OR MAY NOT HAVE CENTER LIFT

**STOCK NO. RP5 (WHITE)**  
**ROAD PLATE (1.25M X 1.25M X 25mm) 301kg**

MAY OR MAY NOT HAVE CENTER LIFT

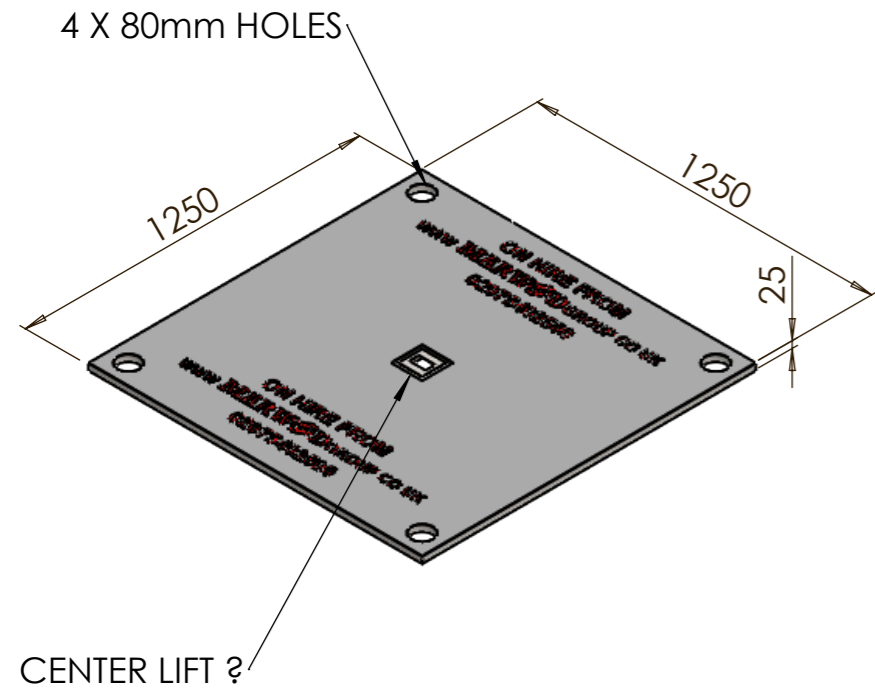

All weights and dimensions have a tolerance of plus minus 0.5%  
 Renders are for illustration purpose only  
 Information on this sheet is correct on date published